

TRUDESIGN™ Ball Valves

Designed and made in New Zealand TRUDESIGN Certified Ball Valves are specifically designed for use in marine applications above and below the water line.

- Certified to ISO 9093-2021 by the International Marine Certification Institute (IMCI, Belgium) when fitted to TRUDESIGN Skin Fittings (Thru Hulls)
- Comply with ABYC H-27 standards when (where needed) used in conjunction with the TRUDESIGN ABYC collar and Skin Fittings (Thru Hulls).
- Certified by Bureau Veritas to ISO 9093-2.

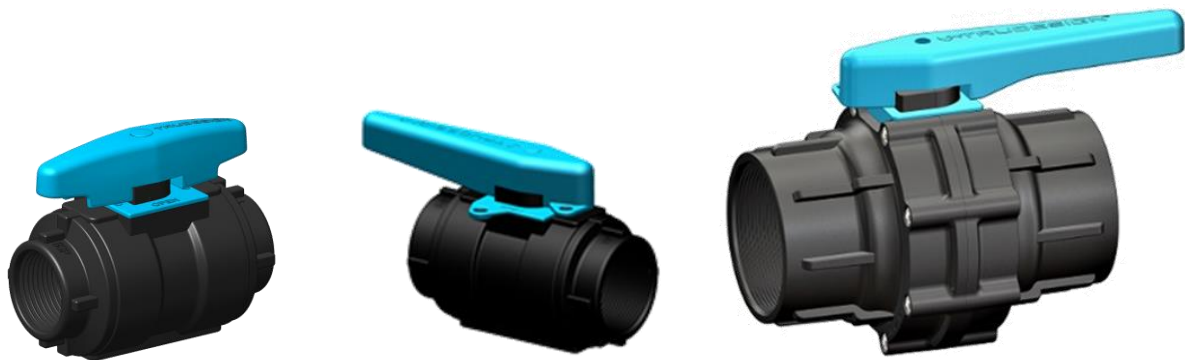

Features

- Manufactured from a glass-reinforced Nylon composite – High strength, tough and light weight.
- Immune to corrosion & electrolysis – No corrosion or breakages, increased safety.
- Electrically non-conductive. No electrical bonding.
- Suitable for use on all hull types - aluminium, steel, wood or FRP.
- The ball and sealing rings utilise a PTFE polymer to ensure a smooth action and minimal fouling of the internal ball.
- The Ball Valve can be locked in the closed position to comply with toilet waste outlet regulations.
- Large operating range – Suitable for all marine conditions from -40°C to $+110^{\circ}\text{C}$
- Available in both BSP and NPS thread forms.
- Can be used in Engine Rooms
- “T” Handle or “Lever” Handle options.
- Handle Identification Tags are available to easily identify Ball Valve Function.
- U.V resistant – No degradation from the sun’s ultraviolet rays.
- 100% leak tested before leaving factory.

Features Continued

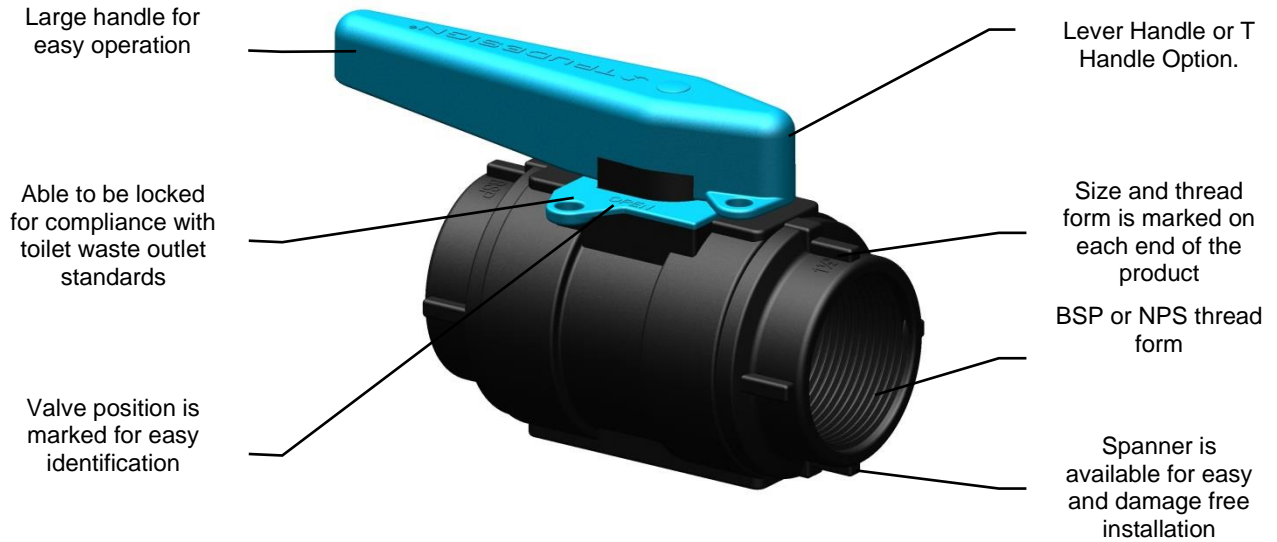

BSP Part Numbers “Lever Handle”

Part Number	Description
90471	Ball Valve ½" BSP
90548	Ball Valve ½" BSP PKG
90276	Ball Valve ¾" BSP
90549	Ball Valve ¾" BSP PKG
90242	Ball Valve 1" BSP
90550	Ball Valve 1" BSP PKG
90240	Ball Valve 1¼" BSP
90551	Ball Valve 1¼" BSP PKG
90235	Ball Valve 1½" BSP
90552	Ball Valve 1½" BSP PKG
90472	Ball Valve 2" BSP
90553	Ball Valve 2" BSP PKG
91157	Ball Valve 3" BSP with Tag

BSP Part Numbers – “T” Handle

Part #	Description
91145	Ball Valve ½" BSP T Handle
91140	Ball Valve ¾" BSP T Handle
91141	Ball Valve 1" BSP T Handle
91142	Ball Valve 1¼" BSP T Handle
91143	Ball Valve 1½" BSP T Handle
91144	Ball Valve 2" BSP T Handle

Note PKG – denotes item packaged in branded plastic Bag

NPS Part Numbers – Lever Handle

Part #	
90647	Ball Valve ½" NPS
90648	Ball Valve ¾" NPS
90649	Ball Valve 1" NPS
90650	Ball Valve 1¼" NPS
90651	Ball Valve 1½" NPS
90652	Ball Valve 2" NPS

Weight

Internal Diameter	Thread Size	Weight (g)	Weight (oz)
19mm [¾"]	½", ¾", 1"	300	10.6
32mm [1¼"]	1¼", 1½"	450	15.9
52mm [2"]	2"	700	24.7
75mm (3")	3"	1,510	53.3

Thread Sealing –

For Thread Sealing Instruction go to our Technical Information Sheet on the TruDesign Website – Scan QR Code



Fitting

Ensure the skin fitting (Thru Hull) and ball valve location enables full operation of the valve handle. See also our info sheet on TRUDESIGN skin fitting installation.

Screw Ball Valve onto the skin fitting (Thru Hull) using the correct Ball Valve Spanner (available from TRUDESIGN), or another appropriate tool. Tighten to a maximum of 16Nm (12ft/lbs).

Check that the final position of the Ball Valve is such that it allows full movement of the handle from the open to closed position, and that it is clear of objects which may cause inadvertent operation.

Note: The connecting threads on each end of the Ball Valves are a parallel thread form. The advantage of parallel threads over tapered is that there is maximum engagement between the mating threads providing a strong and watertight seal. Mixing parallel and tapered threads can cause strength and sealing problems as the engagement can in some cases be only a few turns.

Replacement “T” and “Lever” Handles

Part #	Description
91038	Replacement “T” handle Small – 25mm,19mm,13mm (1”, ¾”, ½”)
91040	Replacement 'T' Handle Large – 50mm-38mm-32mm (2”, 1½”, 1¼”)
91155	Replacement Lever Handle Small 25mm-19mm-13mm (1”, ¾”, ½”)
91156	Replacement Lever Handle Large 50mm-38mm-32mm (2”, 1½”, 1¼”)
91290	Replacement Lever Handle 3”



Ball Valve Spanner

90476	Spanner / Wrench Ball Valve ½” PKG
90477	Spanner / Wrench Ball Valve ¾” & 1” PKG
90478	Spanner / Wrench Ball Valve 1¼” & 1½” PKG
90479	Spanner / Wrench Ball Valve 2” PKG



Ball Valve Handle Tag – Identification Tags are available that easily fit onto the Lever Handles. See Separate Product Information Sheet.



Dimensions -

A	B		C		D		E		F		Lever Handle				T-Handle	
	Size	Length		Length		Height		Width		Minimum Internal Ø		G		H		I
½"	25mm	1"	102mm	4"	88mm	3 4/9"	61mm	2 3/8"	20mm	3/4"	32mm	1 1/4"	93mm	3 2/3"	50mm	2"
¾"	22mm	6/7"	102mm	4"	88mm	3 4/9"	61mm	2 3/8"	20mm	3/4"	32mm	1 1/4"	93mm	3 2/3"	50mm	2"
1"	22mm	6/7"	102mm	4"	88mm	3 4/9"	61mm	2 3/8"	20mm	3/4"	32mm	1 1/4"	93mm	3 2/3"	50mm	2"
1¼"	32mm	1 1/4"	122mm	4 4/5"	102mm	4"	76mm	3"	32mm	1 1/4"	38mm	1 1/2"	108mm	4 1/4"	57mm	2 1/4"
1½"	32mm	1 1/4"	122mm	4 4/5"	102mm	4"	76mm	3"	32mm	1 1/4"	38mm	1 1/2"	108mm	4 1/4"	57mm	2 1/4"
2"	32mm	1 1/4"	141mm	3"	124mm	4 6/7"	99mm	3 7/8"	48mm	1 8/9"	38mm	1 1/2"	108mm	4 1/4"	57mm	2 1/4"
3"	46mm	1 4/5"	205mm	8"	180mm	7"	153mm	6"	75mm	3"	50mm	2"	160mm	6 2/7"	-	-

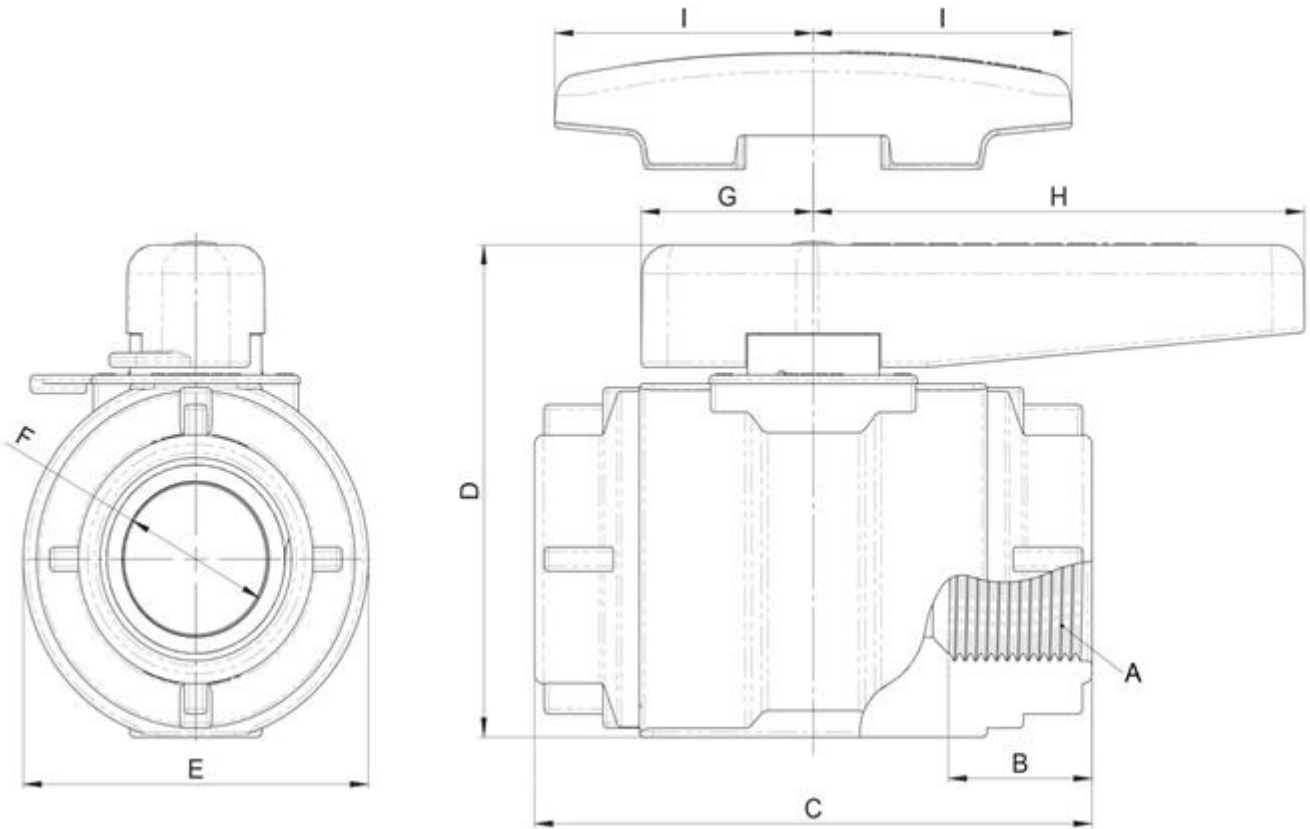

The information contained in this information sheet is for general information purposes only. The information is provided by TruDesign™ and while we endeavour to keep the information up to date and correct, we make no representations or warranties of any kind, express or implied, about the completeness, accuracy, reliability, suitability or availability. Any reliance you place on such information is therefore strictly at your